

An Ultra-Low-Power Filtering Technique for Biomedical Applications

Tan-Tan Zhang, Pui-In Mak, Mang-I Vai, Peng-Un Mak, Feng Wan, R. P. Martins¹

Biomedical Engineering Laboratory, FST and State-Key Laboratory of Analog and Mixed-Signal VLSI,
University of Macau, Macao, China (E-mails: yb07414@umac.mo)

1 – On leave from Instituto Superior Técnico (IST)/TU of Lisbon, Portugal

Abstract—This paper describes an ultra-low-power filtering technique for biomedical applications designated as T-wave sensing in heart-activities detection systems. The topology is based on a source-follower-based Biquad operating in the sub-threshold region. With the intrinsic advantages of simplicity and high linearity of the source-follower, ultra-low-cutoff filtering can be achieved, simultaneously with ultra low power and good linearity. An 8th-order 2.4-Hz lowpass filter design example optimized in a 0.35- μm CMOS process was designed achieving over 85-dB dynamic range, 74-dB stopband attenuation and consuming only 0.36 nW at a 3-V supply.

I. INTRODUCTION

Low power consumption portable biomedical devices perform an important role in daily life. The reduction of power is related with lifetime extension and typically avoids thermal damages of the tissues in multichannel implantable systems. Portability brings also comfort to human beings. The development of integrated circuit (IC) technology allowed a large number of portable, battery operated devices for biomedical applications to enter the markets.

In those applications, filters are one of the most significant building blocks usually employed to enhance signal quality. For some kinds of biomedical signals processing, as the detection of a cardiac signal, an ultra low cutoff frequency LPF is required in order to limit the frequency band.

Biomedical signals are characterized by low frequencies and low amplitudes, and they imply the utilization of lowpass filters (LPFs) with very large time constants using acceptable capacitors' values. Meanwhile, they require very challenging specifications such as high dynamic range, low distortion, low noise, low power and small size. Several techniques have been proposed to overcome the design constraints. The use of switched capacitor (SC) circuits [1] is not suitable for most biomedical applications due to the leakage problem of advanced processes. On the other hand, active-RC circuits using operational amplifiers, resistors and capacitors obtain high linearity at the cost of large chip area and power. Furthermore, the operational transconductance amplifier-

capacitance (OTA-C) topology is popularly utilized in ultra low cutoff frequency filter designs, due to its inherent current cancellation and current division techniques, to implement lower transconductance (g_m) OTAs, thus relaxing the capacitance requirements [2]. Nevertheless, the transconductance of the OTA is not suitable below 1 nA/V namely because of the main tradeoff between noise and linearity. Practically, the required capacitor's value will be still large and the OTAs' circuit structures complicated.

In this paper, the alternative design of an ultra low power and ultra low frequency 8th-order LPF based on the source-follower topology is presented. The largest capacitor value is 8 pF and the filter consumes sub-nano-Watt power under a 3-V supply. Section II discusses the source-follower in terms of its linearity and noise. Filter implementation based on cascade source-followers is presented in Section III. Section IV exhibits the simulation results. Finally, the conclusions are given in Section V.

II. SOURCE-FOLLOWER FILTER

A. Source-Follower-based Uniquad Cell

A source-follower with a capacitive load can be considered a Uniquad cell (1st order) LPF, as shown in Fig. 1(a). M_{n1} is the input transistor while M_{n2} is operating as a current source. C_L is the capacitive load. The small signal model of this circuit at low frequency is depicted in Fig. 1(b). Here, g_{mbn1} and g_{mn1} are the bulk transconductance and gate transconductance of M_{n1} , respectively. On the other hand, V_{gsn1} and V_{bsn1} are the gate-source voltage and the bulk-source voltage of M_{n1} , and where r_{o_n1} and r_{o_n2} are the output resistances of M_{n1} and M_{n2} . Based on this, the transfer function can be expressed as:

$$H(s) = \frac{g_{mn1}}{g_{mn1} + g_{mbn1} + \frac{1}{r_{o_n1}} + \frac{1}{r_{o_n2}} + sC_L} \quad (1)$$

From (1), the value of the bulk transconductance g_{mbn1} will contribute for the DC-gain reduction of the filter, but, this

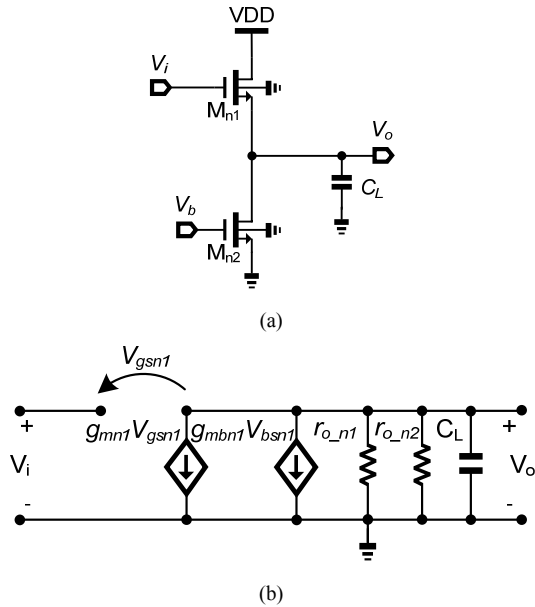

Fig.1 Source-follower with capacitive load: (a) Circuit schematic; (b) Low-frequency small-signal model.

term can be eliminated by connecting the bulk to the ground ($V_{bs}=0$). However, this possibility is only available for PMOS transistors in CMOS processes with N-well [3].

The intrinsic features of this topology are the following [4]:

- Simplicity in terms of analysis (e.g., one pole) and implementation (e.g., just two devices).
- Good linearity due to its feedback.
- Distortion induced by the voltage to current conversion is avoided since the filtering is operated in terms of voltage.
- Low output impedance, with potential to drive a wide range of loads, and with negligible effects on filter's linearity, not affecting the transfer function as well.

B. Source-Follower-based Biquad Cell

For a sharper attenuation profile of the LPF, the utilization of complex-conjugate poles is always mandatory. To achieve a second-order transfer function, a Biquad cell based on the source-follower is depicted in Fig. 2(a), in which C_1 can be gyrated as an inductor at the source terminal of M_{n1} . Then, a pair of complex-conjugate poles is realized with C_2 . The fully-differential structure of this Biquad cell is shown in Fig. 2(b).

For simplicity of the calculation, the stacked transistors are considered to have the same transconductance (g_m), while, the

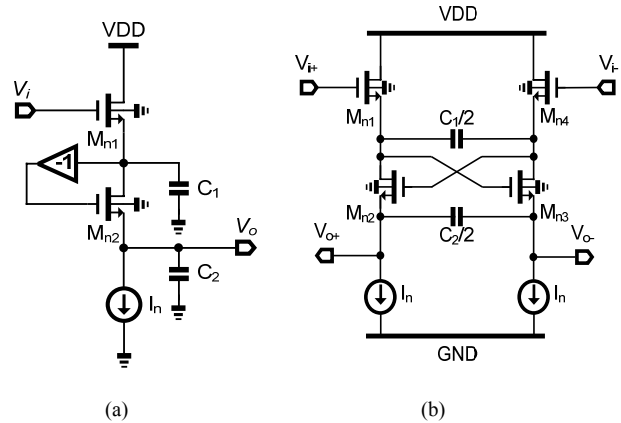

Fig.2 (a) Single-ended Biquad cell (b) Fully-differential Biquad cell.

output resistors are assumed to be much larger than $1/g_m$. The transfer function of the Biquad cell can be derived as:

$$H(s) = -\frac{1}{s^2 \frac{C_1 \cdot C_2}{g_m^2} + s \frac{C_1}{g_m} + 1} \quad (2)$$

With the cutoff frequency ω_0 given by:

$$\omega_0 = \frac{g_m}{\sqrt{C_1 C_2}} \quad (3)$$

From (3), to achieve an ultra low cutoff frequency, the transconductance (g_m) should be very small while acceptable on-chip capacitors are employed. Typically, for the implementation of a 5-Hz pole, when a reasonable on-chip capacitor of 20 pF is used, a transconductance (g_m) of 150 pA/V is required. Thus, the transistors in the Biquad cell operate in the sub-threshold region to minimize the value of g_m , which is given by (4). In (4), 'n' is the sub-threshold slope factor and it has a value close to 1.5. ' U_T ' is the thermal voltage, being close to 26 mV at room temperature. g_m depends only on the DC bias current I_D . Low cutoff frequency requires low transconductance, resulting in low power consumption. Hence, the source-follower topology is the correct choice for low power and low frequency designs.

$$g_m = \frac{I_D}{nU_T} \quad (4)$$

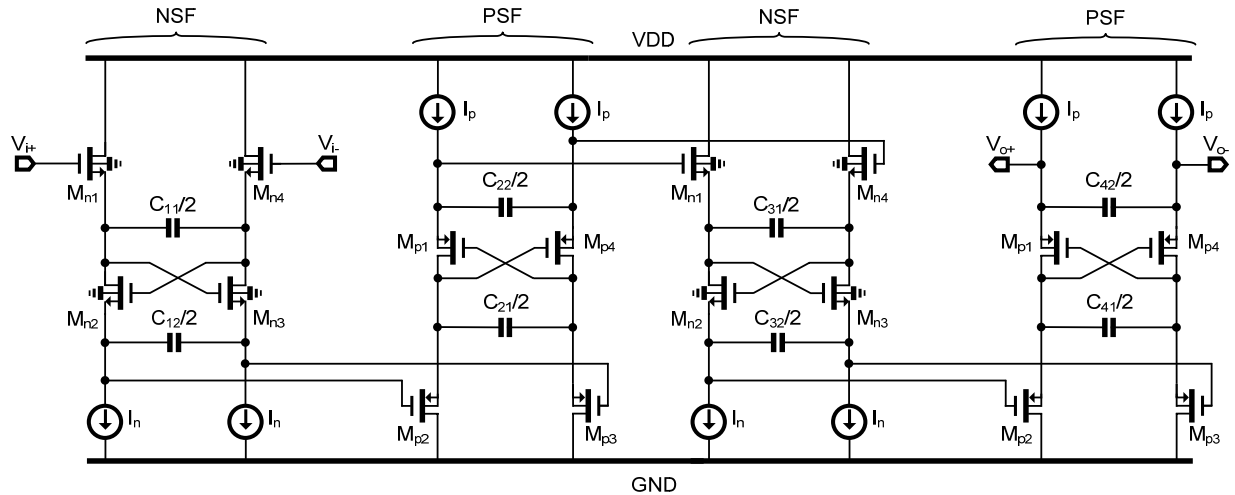

Fig.3. The circuit architecture of the proposed 8th-order source-follower-based LPF.

III. PROPOSED SUB-THRESHOLD-BIASED LPF

In some biomedical applications a LPF with cutoff frequency of several Hertz and adequate attenuation is required. For example, it can be used to sense the T-wave of cardiac signal, which represents the recovery of the ventricles. In this paper, a 2.4-Hz ultra low power 8th-order source-follower based Butterworth LPF with a maximum flat response is designed. The details are presented next.

A. Filter architecture

The proposed 8th-order LPF architecture satisfying typical specifications for biomedical applications is depicted in Fig. 3, as a cascade of 4 Biquad cells that include PMOS source-follower (PSF) and NMOS source-follower (NSF). The cascading allows the compensation of input-output common-mode voltage difference. The quality factor of each Biquad cell, highly dependent on the capacitance values, has been properly designed to implement a Butterworth LPF.

B. Linearity

The source-follower topology exhibits high linearity due to the inherent feedback. The linearity of the filter is evaluated through its harmonic distortion. Even harmonics are ideally cancelled due to a differential topology and the third harmonic will be dominant. The distortion mainly stems from the body effect in ultra low frequency of operation. Thus, the PSF operates with less distortion and is deliberately placed as the output stage to optimize the overall linearity. On the other hand, larger channel length means smaller channel length modulation and improves the linearity, because of that transistors have been designed with 50 μm channel length and the bias current is 10 pA.

C. Noise performance

The dominant noise in the passband is the thermal noise because large gate transistors are utilized, which efficiently suppress the flicker noise. The thermal noise is determined by kT/C , where k is the Boltzmann constant, and T is the absolute temperature. The most effective way to decrease the thermal noise voltage is to increase the capacitor values. However, this will imply a larger silicon area and consequently, it will lead to more power to obtain larger transconductance and maintaining the same cutoff frequency according to (3).

IV. SIMULATION RESULTS

The proposed ultra-low-power 8th-order source-follower based low pass filter is designed and simulated in 0.35- μm CMOS, with *Spectre* as the simulator. The magnitude response of the filter is shown in Fig. 4, where it can be observed that the -3-dB frequency is close to 2.4 Hz.

The DC-gain is -7.8 dB, instead of the ideal 0 dB in the passband, which is mainly due to the pronounced bulk transconductance of NMOS transistors. The stopband attenuation is around 160 dB per decade which is adequate for avoiding noise aliasing into the signal band. To evaluate the linearity, a 50-mV_{p-p} sinusoidal wave input at 0.5 Hz is applied.

The simulated third harmonic distortion is below -85.5dB, as shown in Fig.5. Even-order distortion is cancelled by the fully-differential structure, but it is still considerable when compared with the odd-order harmonic. This is due to the ultra low bias current, which degrades the matching between the transistor pairs.

The output referred noise density of the filter is shown in Fig. 6. The thermal noise is dominant, i.e. kT/C noise, which is dependent on the capacitor values. The integrated output referred noise over the band of 0.1-2.4 Hz is below 45 μV .

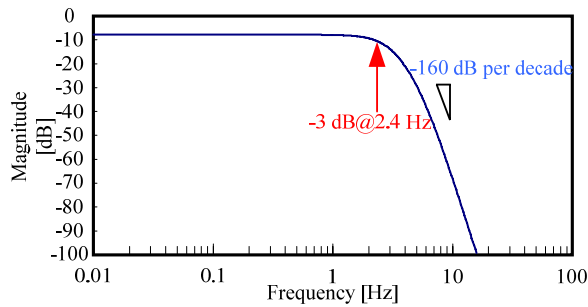

Fig. 4 Magnitude response of the LPF filter.

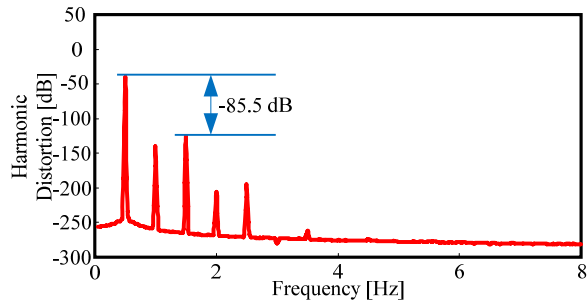

Fig. 5 Harmonic distortion with 50mV p-p @ 0.5 Hz input.

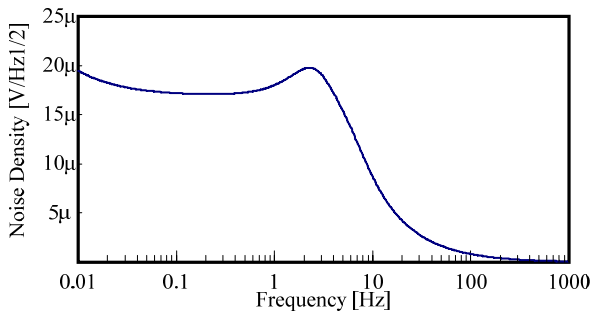

Fig. 6 Output-referred noise density of the filter.

The simulated results are summarized in Table I and a benchmark is made with other works. This design presents many advantages, namely, the ultra low power, high dynamic range and robust stopband attenuation.

V. CONCLUSIONS

An ultra-low-power filtering technique based on a source-follower structure has been presented. To demonstrate its effectiveness a design example of an 8th-order Butterworth LPF, optimized in 0.35- μ m CMOS, has been developed, achieving 85-dB dynamic range, 74-dB stopband attenuation, consuming 0.36 nW with a 3-V supply. When comparing it with prior arts, the proposed LPF based on sub-threshold-biased source-followers exhibits outstanding performance, with the necessary features (e.g., ultra low power, low noise and high linearity) for future nW-class biomedical systems.

TABLE I. PERFORMANCE SUMMARY AND BENCHMARK

Order and Topology	6 th Single-ended (Measured) [5]	5 th Fully - differential (simulated) [6]	8 th Fully-differential (simulated) This work
Bandwidth	2.4 Hz	2.4 Hz-10 kHz	2.4 Hz
Technology	0.8 μ m CMOS	0.35 μ m CMOS	0.35 μ m CMOS
Integrated input referred noise @ 0.1 -2.4 Hz	50 μ V	159 μ V	113 μ V
HD ₃ @ V _{in} =50mV p-p	<-60 dB	<-80 dB	<-80 dB
Dynamic Range	>60 dB	>68 dB	>85 dB
Stop band Attenuation @ Half a Decade	40 dB	>64 dB	>74 dB
Power Consumption	10 μ W	28 μ W	0.36 nW
Supply Voltage	\pm 1.5 V	3 V	3 V

ACKNOWLEDGEMENT

The authors would like to thank Mr. Chen Changhao for the valuable discussion. This work is financially supported by the Research Committee of University of Macau and Macao Science and Technology Development Fund (FDCT).

REFERENCES

- [1] W. Sansen and P. M. Van Peteghem, "An area-efficient approach to the design of very-large time constants in switched-capacitor integrators," *IEEE JSSC*, vol. SC-19, pp. 772–780, Oct. 1984.
- [2] J. Silva-Martinez and J. Salcedo-Suñer, "IC voltage-to-current transducers with very-small transconductance," *Analog Integrated Circuits Signal Proc.*, vol. 13, pp. 285–293, 1997.
- [3] D.M. Binkley, *Tradeoffs and Optimization in Analog CMOS Design*: WILEY Press, 2008.
- [4] S.D'Amico, Matteo Conta and Andrea Baschiroto, "A 4.1-mW 10MHz Fourth-order Source-Follower-Based Continuous-Time Filter with 79-dB DR", *IEEE JSSC*, vol.41, No. 12, pp. 2713-2718, Dec. 2006.
- [5] S. Solis-Bustos, J. Silva-Martinez, F. Maloberti, and E. Sanchez-Sinencio, "A 60-dB dynamic-range CMOS sixth-order 2.4 Hz Low-pass Filter for medical applications," *IEEE Trans. Circuits Syst. II*, vol. 47, No. 12, pp. 1391–1398, Dec. 2000.
- [6] Chang-Hao Chen, Pui-In Mak, et al., "A 2.4 Hz-to-10 kHz-Tunable Biopotential Filter Using a Novel Capacitor Multiplier," *IEEE Asia Pacific Conference on Postgraduate Research in Microelectronics & Electronics (PrimeAsia)*, pp. 372-375, Nov. 2009.