

Reconfigurable mismatch-free time-interleaved bandpass sigma-delta modulator for wireless communications

Dongyang Jiang, Sai-Weng Sin[✉], Seng-Pan U, Rui Paulo Martins and Franco Maloberti

A reconfigurable bandpass time-interleaved sigma-delta modulator to achieve a wide tuning range is presented. With the calculated control parameters, the interleaving mismatch tones can always be shifted out of the interesting band during the whole tuning range, allowing always a mismatch-free implementation. The proposed method adopts a look-up table to obtain the various parameters including path numbers, path sampling frequencies, and tuning coefficients. With higher levels of reconfigurability the design meets the requirements of a multiband receiver for software defined radio systems, and the technique verified by behavioural simulations that also confirm the performance.

Introduction: In recent years, the rapid development of wireless systems pushes the demand for a single chip solution with high speed, low power, and multi-standard requirements. One trend is to shift more analogue functions into the digital domain, hence the analogue-to-digital converters (ADCs) can be placed directly after the low-noise amplifier to sample the radio-frequency (RF) signals. In such applications like software defined radio (SDR), designers prefer to use bandpass sigma-delta modulator (SDM) since it is a waste to sample the signal outside the channel bandwidth. To digitise up to GHz RF signals, parallelism, implemented by time-interleaving (TI) N -path, is a possible solution [1]. In such N -path SDM, each path operates at f_s/N , where f_s and N represent the total sampling frequency and the total number of paths, respectively. Nevertheless, once we do interleaving at the circuit level, imperfect operations of ADCs including offset, gain, and timing mismatch cause spurs at the output spectrum. These mismatch spurs not only result in an overall reduction in dynamic range but also limit the overall tuning range; that is why they become the major drawback of the traditional time-interleaving.

In this Letter, the proposed method simply utilises the reconfigurable feature of the time-interleaved SDM to avoid the collision between the mismatch tones and the signal band. Regarding the tuning, without changing the analogue blocks of the main path, the desired noise shaping can be attained by modifying the coupling matrix [2]. For further precise control, a look-up table governs the programmable parameters. Fig. 1 depicts the complete system block diagram.

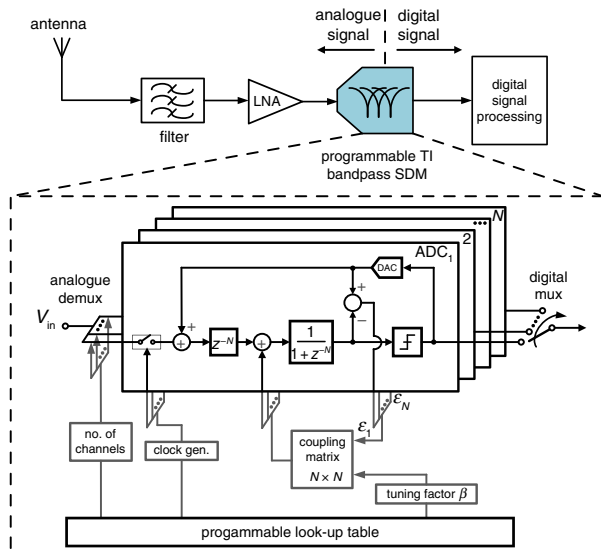

Fig. 1 Proposed reconfigurable N -path first-order bandpass SDM with noise-coupling tuning in the wireless receiver

Avoidance of mismatch collision: For Nyquist ADCs, the performance is fundamentally limited by mismatch spurs, as the signal band covers the full first Nyquist band, including all these spurs inside. However, for SDMs, the interesting characteristic is that we only need to care about the narrow-band due to the oversampling feature, and finally all

the outside spurious tones can be removed later by the decimation filter in the subsequent digital processing. The literature research for the TI-Nyquist converter in [3] shows that the mismatch spurs location is convincingly related with the number of paths and the sampling frequency. With a sinusoidal input, the offset, gain, and timing mismatches in the TI system generates the error tones at

$$\begin{cases} f_{\text{offset_spur}} = k \times f_s/N, \\ f_{\text{gain,timing_spur}} = \pm f_{\text{in}} + k \times f_s/N, \end{cases} \quad k = 1, 2, 3, \dots, N-1 \quad (1)$$

Fig. 2 illustrates the methodology for avoiding mismatch crash. For easier explanation, we set the maximum reconfigurable $N=4$, and all the remaining developments follow this assumption. Fig. 2a shows when the input signal moves towards $3f_s/8$, the most threatening spur should be the spur arising at $3f_s/4 - f_{\text{in}}$, and a collision between the signal and this mismatch tone is inevitable. Such observation clearly demonstrates the whole tuning range is inherently limited by the mismatch spurs in the TI structure. In our proposed reconfigurable SDM, the switching from 4X to 3X interleaving can eliminate the collision. Fig. 2b shows that as we switch the working path numbers to 3, the mismatch spurs also change. A new dc offset located at $f_s/3$ now becomes the threatening spur, thus the whole tuning range can be extended until another collision happens. In the SDR receiver, normally the signal bandwidth is narrow when comparing with the entire signal band, leaving enough margins for such operation. Similarly, the transfer from 3X to 2X interleaving (when f_{in} is near $f_s/3$) also follows such strategy.

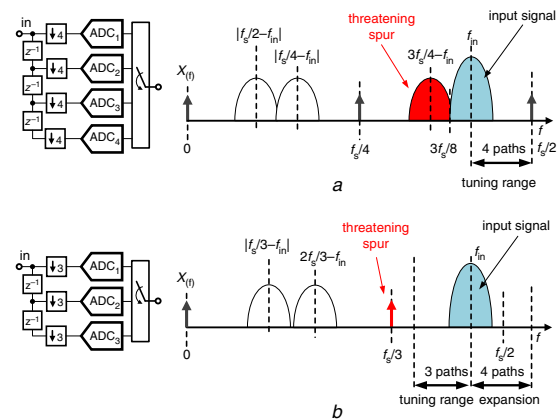

Fig. 2 Working paths' switching from 4X to 3X interleaving
a 4X interleaving spurs inside first Nyquist output spectrum
b 3X interleaving spurs inside first Nyquist output spectrum

Based on the above, the jump of path numbers can avoid the overlapping between mismatch tones and the interesting band. In a short conclusion, the whole tuning frequency range R now equals the union of available intervals contributed by different interleaving conditions:

$$R = \bigcup_{k=2}^N R_{k\text{-path}} \quad R_{k\text{-path}} = \left(\frac{k-1}{2k} f_{s,k\text{-path}} + \frac{BW}{2}, \frac{f_{s,k\text{-path}}}{2} - \frac{BW}{2} \right) \quad (2)$$

Furthermore, with the setting in the look-up table, the system can adapt to the centre frequency's location, and change the working path numbers on demand, consequently relaxing the speed requirement of individual ADCs, and allowing their usage in a smart and cost-effective manner.

Realisation of tunable noise transfer functions (NTFs): The traditional NTF with zeros at $z = e^{\pm j\alpha}$ for a two-path bandpass SDM is as follows:

$$\text{NTF} = 1 + \beta z^{-1} + z^{-2} \quad (3)$$

where $\beta = -2\cos(\alpha)$ is the crossed-coupling coefficient between 2 paths. Interestingly, the N -path scheme will do the transformation of $z \rightarrow z^N$ automatically as each path is running at $1/N$ of the total speed. It can be deduced that when the formula in (3) extends to 3 paths, the main path raises the order to $\text{NTF} = 1 + z^{-3}$ and so forth. Such characteristic leads to the need for evolving the conventional second-order bandpass SDM into high order cases. In general, the uniform NTF for N -path is

given by

$$\text{NTF}_{N\text{-channels}} = 1 + k_1 z^{-1} + k_2 z^{-2} + \dots + k_{N-1} z^{N-1} + z^{-N} \quad (4)$$

The above scheme can be implemented by the N -path architecture [4], As illustrated in Fig. 3, the main path can offer the transfer function of $\text{NTF} = 1 + z^{-N}$, while the remaining polynomial term can be formed by the injection of coupling noise derived from the quantisers.

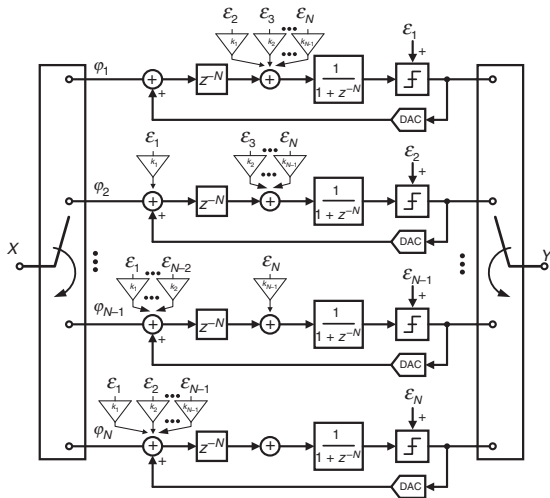

Fig. 3 N -path TI noise-coupling SDM with crossed tuning coefficient

The third-order NTF could be obtained by multiplying (3) by $1 + z^{-1}$. Squaring (3) brings the fourth-order NTF, and higher order cases also follow such operation of adding zeros on the unit circle. Table 1 shows the coupling values' assemblage up to 4 paths. By this way, when changing the path numbers, only the coupling coefficients' matrices need to be changed for tuning the centre frequency, while the remaining integrators as well as the delay blocks, can be reused.

Table 1: The tuning coefficient table for (4) when $N \leq 4$

	Coupling coefficients
$N=2$	$k_1 = \beta$
$N=3$	$k_1 = 1 + \beta; k_2 = 1 + \beta$
$N=4$	$k_1 = 2\beta; k_2 = 2 + \beta^2; k_3 = 2\beta$

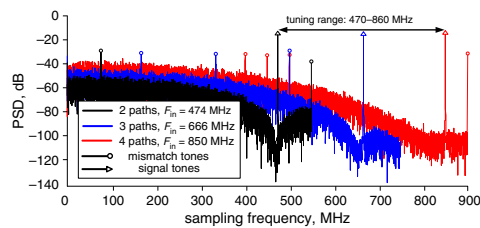

Fig. 4 2,3,4-Path output spectrum of the tunable SDM

Design example: For receiving the digital video broadcasting-terrestrial (DVB-T) signal in an SDR application, we designed an example for sampling ultra-high frequency (UHF) television signals (470–860 MHz). To validate the tuning ability, the time-interleaved SDM is reconfigurable with 2, 3, and 4 paths. While UHF bands have many channels with a uniform spacing of 8 MHz, with the only selected values listed in Table 2 for the demonstration, because they already cover the whole UHF band to ensure mismatch-free operation under (2). With a 4-bit quantiser working in each path, the testing model was built and evaluated using MATLAB with SIMULINK. Fig. 4 shows the spectrum of the simulated system. Following the band setting, all the mismatch spurs are outside the band of interest. The signal-to-noise ratio of each case is beyond 60 dB, satisfying the requirement for the digital TV standard. In practical circuits, the four-path case produces a fourth-order NTF that may be too aggressive when compared with the two-path case, thus wasting the opamp power. Such waste indeed can be compensated by reducing the opamp bias current in the four-path since the signal-to-quantisation-noise ratio in such case will be quite large, thus allowing margins for power reduction.

Table 2: The whole band settings with interleaving spurs listed inside first Nyquist output spectrum

Channel signal (MHz)	Path	F_s (MHz)	Signal band (MHz)	Offset mismatch spurs (MHz)	Gain, timing mismatch spurs (MHz)
850	4	1800	847–853	450,900	50,400,500
826	4	1800	823–829	450,900	74,376,524
794	4	1800	791–797	450,900	106,344,556
762	4	1800	759–765	450,900	138,312,588
730	4	1800	727–733	450,900	170,280,620
698	4	1800	695–701	450,900	202,248,652
666	3	1500	663–669	500	166,334
634	3	1500	630–637	500	134,366
602	3	1500	599–605	500	102,398
570	3	1500	567–573	500	70,430
538	2	1100	535–541	550	12
506	2	1100	503–509	550	44
474	2	1100	471–477	550	76

Conclusion: This Letter presents a reconfigurable TI bandpass SDM. By switching the working paths to avoid spurs, the SDM achieves a wide tuning range. Also, the cross-coupled coefficients are derived and then followed by computer simulations that validate the tuning approach. The proposed architecture opens new perspectives for the design of bandpass SDM integrated into high-speed wireless applications.

Acknowledgments: This work was financially supported by the Research Committee of the University of Macau and the Macao Science & Technology Development Fund (FDCT) under the project SKL/AMS-VLSI/SSW/FST.

© The Institution of Engineering and Technology 2017
Submitted: 2 January 2017 E-first: 24 February 2017
doi: 10.1049/el.2016.4623

One or more of the Figures in this Letter are available in colour online.

Dongyang Jiang, Sai-Weng Sin, Seng-Pan U and Rui Paulo Martins (State-Key Laboratory of Analogue and Mixed-Signal VLSI, Department of ECE, FST, University of Macau, Macao, People's Republic of China)

✉ E-mail: terrysw@umac.mo

Franco Maloberti (IMS, Pavia University, Pavia, Italy)

Rui Paulo Martins: Also with Instituto Superior Técnico (IST), Universidade de Lisboa, Lisboa, Portugal

References

- Ong, A.K., and Wooley, B.A.: 'A two-path bandpass SD modulator for digital IF extraction at 20 MHz', *IEEE J. Solid-State Circuits*, 1997, **32**, (12), pp. 1920–1934
- Hamidi, B., and Miar-Naimi, H.: 'Extended noise shaping in sigma-delta modulator using cross-coupled paths', *IEEE Trans. Circuits Syst. I*, 2014, **61**, (6), pp. 1675–1686
- Kurosawa, N., Kobayashi, H., Maruyama, K., *et al.*: 'Explicit analysis of channel mismatch effects in time-interleaved ADC system', *IEEE Trans. Circuits Syst. I*, 2001, **48**, (3), pp. 261–271
- Feng, D., Maloberti, F., Sin, S.W., and Martins, R.P.: 'Polyphase decomposition for tunable band-pass sigma-delta A/D converters', *IEEE J. Emerg. Sel. Top. Circuits Syst.*, 2015, **5**, (4), pp. 537–547